

Optional Load Cell for Sensing Force and Tension

Integral Force Sensing Actuators

Sensing Accuracy When you Need It

By sensing motor current, brushless servo technology can measure motor current to an accuracy of about 10%. This equates to torque measurement in a rotary servo motor and force in a linear servo actuator.

When your application requires higher accuracy, Exlar offers load cell technology embedded in the actuators for convenience and a clean package.

Applications that utilize load sensing include but are not limited to:

- ◆ Fastening and Joining
- ◆ Riveting
- ◆ Bag Sealing
- ◆ Thermoforming
- ◆ Injection Molding
- ◆ Precision Pressing
- ◆ Fillers
- ◆ Formers
- ◆ Precision Grinders
- ◆ Clamping
- ◆ Interference detection

- ◆ Die Cutters
- ◆ Lifts
- ◆ Molding
- ◆ Welding
- ◆ Tube Bending
- ◆ Stamping
- ◆ Test Stands
- ◆ Tension Control
- ◆ Wire Winding
- ◆ Parts Clamping
- ◆ Dispensers

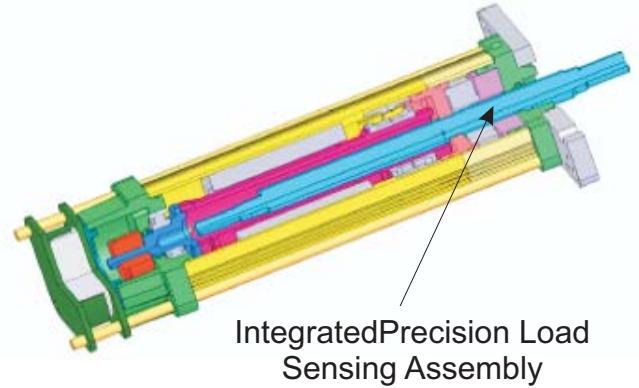
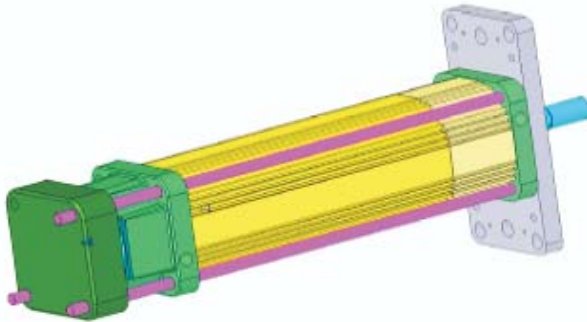

Integrated Precision Load Sensing Assembly

Features

- Integrated strain gauge load cell
 - ◆ 10 VDC External Excitation
 - ◆ 2 mV/V sensitivity
 - ◆ 4000 lbf Tension or Force Measuring
 - ◆ 2% full load linearity
 - ◆ 200 Hz Frequency Response
 - ◆ Factory Calibrated
- Compatible with standard strain gauge monitors and PLC cards
- Totally enclosed within the actuators sealed housing and connectorized for ease of use
- Available in Exlar's GSX40 linear actuator

Call us Today!

Contact us at **952-368-3434** to discuss your application. You may also visit www.exlar.com to locate the sales rep nearest you.

EXLAR

Exlar GSX40 Load Cell Option

Overview

Exlar offers its robust line of GSX40 actuators with an integrated load cell for load sensing. The load cell is a strain gauge type, offering you stable and accurate load sensing in both the tension and compression directions, and for static or dynamic loads. The packaging of the strain gauges are integral to the actuators housing, offering a compact, protected, robust design.

Configuration

The load cell is factory preloaded to approximately 10,000 pounds. This preload will vary with time and temperature. This preload can be measured by applying the 10V excitation and reading the mV output, and scaling the output by the calibration factor.

“Load cell amplifiers' commonly used with load cells contain power, excitation, and signal conditioning. These modules will typically amplify the output signal to volts rather than milli-volts. These types of devices may be stand alone devices made for mounting in an electrical panel, incorporated into panel meters with digital displays, or, integral to a PLC or other control device.

The mechanical efficiency of the entire system that a load measuring device is mounted into is important to the overall accuracy of the measurement. The more mechanically efficient the system is, the more accurate the load sensing will be. So, it is important to take care in the mounting of the actuator, and the design of the overall system to minimize unneeded friction and other inefficiencies.

Operation

Operational Example: If the calibration factor is 1.656 mV/V at full load, and the excitation supply is 10 volts, and the output signal is .894 mV, then without any external load on the actuator, the preload is:

$$Q = .894 \times 20000 / (1.656 \times 10) = 1086 \text{ pounds}$$

At application of load, sample the signal and compare to unloaded value. The result is the load.

Example: Given the preload Q of 1086 pounds, and the signal after a load is applied is .338 mV, what is the load?

$$P = (.894 - .338) \times 20000 / (1.656 \times 10) = 671 \text{ lbs.}$$

Note a positive value indicates the load is a compressive load on the actuator rod and a negative value indicates a tensile load on the rod actuator.

Specifications and Calibration Data

Specifications

Excitation: 10VDC
Input Impedance: 352 Ohms
Output Impedance: 353 Ohms
Electrical Leakage: Infinite Meg Ohm

Capacities:

100 – 4000 lbs
200 Hz frequency response

Standard Connector Wiring Information

Pin	Function	
A	(+) Excitation	10V
B	(-) Excitation	
C	(-) Output	
D	(+) Output	
E		
F	Shield	
G		
H		



Exlar Corporation
1470 Lake Drive West
Chanhassen, MN 55317
Tel: 952-368-3434
Fax: 952-368-4359
www.exlar.com