

Force Measuring Actuators

Exlar offers select models of its GSX and I Series actuators with integral force measuring capability. This option is available in the GSX30, 40, 50 & 60 models and the I30 and 40 models.

In both product lines a load cell is embedded within the actuator allowing it to directly measure the force being applied by the actuator's output rod. The strain gauge load sensor used to measure applied force is mounted inside the actuator's case, protecting it from external damage and guaranteeing accurate and consistent force data.

A separate connector is supplied for connecting the internal load cell to an external strain conditioner/amplifier required to excite the strain gauge sensor. Alternatively, Exlar can offer strain gauge conditioners to provide a high level output signal, either 0-10V or 4-20mA.

Alternatively, any one of numerous conditioners/amplifiers available can be used for this purpose.



Strain Gauge Amplifier

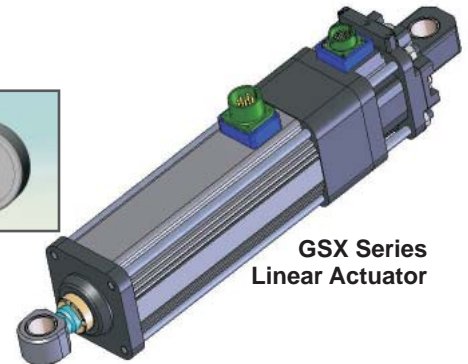

GSX Series
Linear Actuator



I Series
Linear Actuator

Applications

- Fastening and Joining
- Riveting
- Bag Sealing
- Thermoforming
- Welding
- Fillers
- Formers
- Clamping
- Molding
- Precision Grinders
- Precision Pressing
- Interference Detection
- Die Cutters
- Injection Molding
- Tube Bending
- Stamping
- Test Stand Lifts
- Tension Control
- Wire Winding
- Parts Clamping
- Dispensers
- Circuit Board Testing
- Blood Processing

Features

- Measuring of compressive loads with optional bi-directional load measurement
- Integrated strain gauge load cell
- 10 VDC external excitation
- 2 mV/V sensitivity
- +/- 1% linearity
- +/- 0.5% repeatability
- Hysteresis, 1% nominal
- 250 Hz frequency response
- Factory calibrated
- Compatible with standard gauge monitors and PLC strain gauge input cards
- Requires external excitation
- Totally enclosed within the actuator's sealed housing, and connectorized for ease of use

Achieving Precise Measurement

Frequently industrial applications involving linear actuation require the precise measurement of the load being applied by the actuator. Historically these have been accomplished by placing a load cell between the actuator and the connection to the workpiece.

This approach provides several challenges. Load cells need to be sized, selected and ordered. Mechanical linkages and mountings need to be designed, built and assembled. Precise alignment must be maintained to prevent bending moments which can severely degrade the accuracy of any load measurement system involving load cells.

Provisions for securing the wires to the load cell need to be designed particularly if the load cell is moving in the process of applying the force. Moving wires are extremely prone to failure and consideration must be given to the amount of flexing. Lastly, a

strain gauge signal conditioner must be selected, ordered, installed and calibrated.

What seems on the front end to be a simple implementation of a force measuring system frequently turns into a project requiring expertise from both electrical and mechanical personnel. It is also common to see such projects extend beyond the target completion date as system components are redesigned or reordered.

Exlar's embedded force measuring option eliminates much of the effort and the risk associated with measuring the applied force produced by the actuator. This system will deliver specified performance and allow you to meet target dates as all design work is field-proven and factory-tested by Exlar.

Flexing cables are not necessary. The actuator body typically does not move as it applies force. The force signal cable can be run alongside the actuator's central and power cables. And, the force sensor carries the same IP rating of the actuator since it is located inside the actuator's case.

Typically the load cell's rating is matched to full load capacity of

the actuator. Over-load capacity of a minimum of 2x rating is provided to reduce the possibility of inadvertent load damage due on occasions when higher than planned high peak forces are applied.

Configuration

The standard configurations offer measurement of compressive loads. Optional configurations are available to offer bi-directional measurement of force.

Load cell amplifiers commonly used with load cells contain power, excitation, and signal conditioning. These modules will amplify the output signal from milli-volts to useable levels of 0-10V or 4-20mA. These devices are available as stand-alone devices made for mounting in an electrical panel, incorporated into panel meters with digital displays, or integral to a PLC or other control device.

Exlar's force measuring actuator assemblies are factory calibrated and certified providing you the information needed to quickly and simply set up your measuring system.

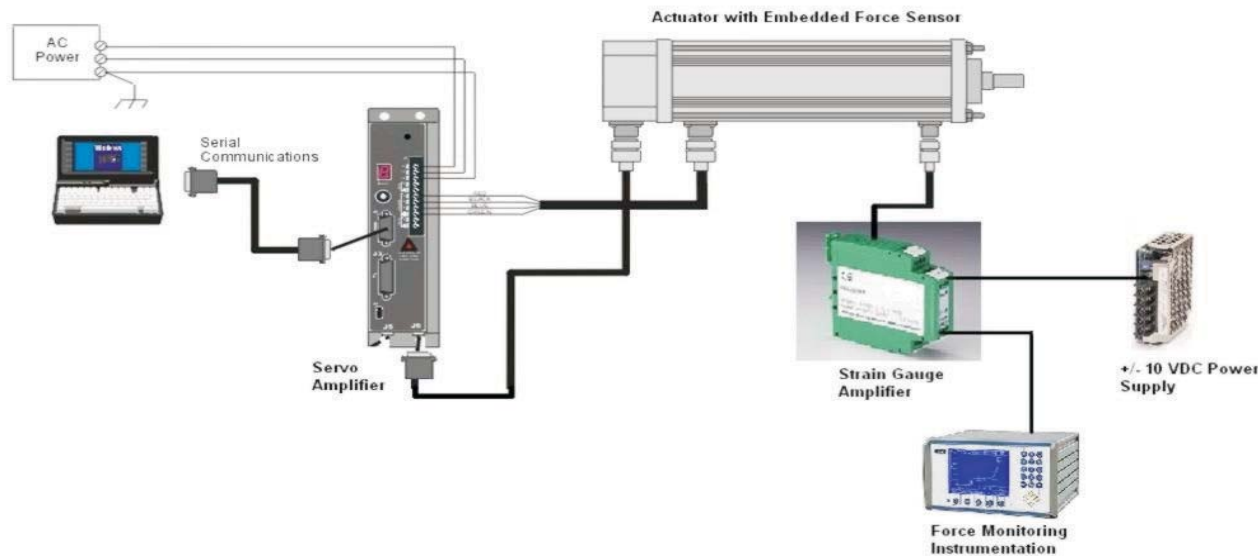

GSX Actuator with Compression Force Measurement, Optional Bi-directional Measurement

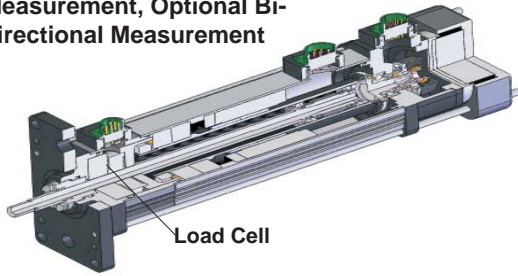

GSX Actuator with Clevis Mount and Compression Only Force Measurement

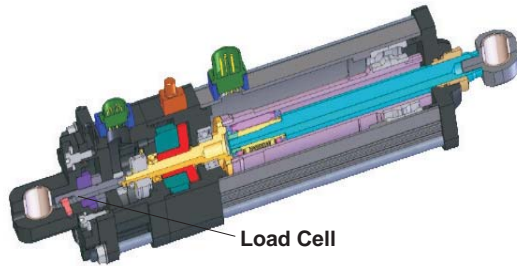

I Series Actuator with Compression Force Measurement

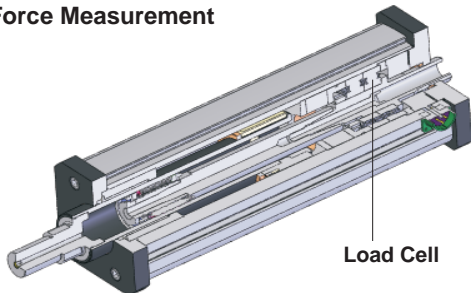

Force Measuring GSX & I Series Actuators

Model	Mount	Force Measurement		Output Rod Diameter
		Compression Only	Option for Tension	
GSX30	Flange	X	X	*
GSX30	Rear Clevis	X		Catalog Std.
GSX40	Flange	X	X	Catalog Std.
GSX40	Rear Clevis	X		*
GSX50	Flange	X	X	*
GSX50	Rear Clevis	X		Catalog Std.
GSX60	Rear Clevis	X		Catalog Std.
I 30	Flange	X	X	Catalog Std.
I 40	Flange	X	X	Catalog Std.

*Reduced from standard actuator rod

Performance Specifications

	GSX Series	I Series
Linearity (% of full actuator max load)	+/- 1%	+/- 1%
Repeatability	+/- 0.5%	+/- 0.5%
Hysteresis	1% Nominal	1% Nominal
Frequency Response*	>250 Hz	>250 Hz
Overload Capability	1.5x Full Scale	1.5x Full Scale
Sensitivity (nominal)	2 mV/V	2mV/V
Bridge Resistance	350 Ohm	350 Ohm
Excitation	10 VDC	10 VDC
Input Impedance	350 Ohms	350 Ohms
Output Impedance	350 Ohms	350 Ohms

*This is the frequency response of a "locked rotor" load cell actuator. Frequency response of the load cell/actuator system will depend on total system inertia and the motor and drive amplifier powering the system.

Force Measuring Actuator Range/Capacity

Frame	30	40	50	60
GSX Series Force/Tension* Measurement Range/Capacity lbf (kN)	50-1300 (0.2 - 5.78)	100-4000 (0.4 - 7.8)	250-8000 (1.1- 36)	500-10000 (2.2 - 45)
I Series Force/Tension Measurement Range/Capacity lbf (kN)	50 - 1300 (0.2 - 5.78)	100-4000 (0.4 - 17.8)		

*Tension optional

Strain Gauge Amplifiers

All Exlar precision load measuring designs are incremental in nature. By this it is intended that force measurements always be conducted as the change in the signal output between the start of each load producing motion and its completion. The force measuring option is not intended to be used as an absolute measurement of force being applied.

Exlar can provide strain gauge amplifiers that offer a convenient method for accurately and reliably measuring the resistance change per cycle of the strain gauge load cell embedded in either a GSX or I Series actuator.

These units convert the small mV changes in load cell output to a 0-10 volt or 4-20 mA signal which is proportional to the load or tension being applied by the actuator. These amplifiers can be DIN rail or panel mountable, with or without displays.

Typical Features

- DIN rail panel
- 24 Volt power
- +/- Volt or 0/4-20 mA output
- Simple gain & offset adjustments
- Auto calibration
- Simple filtering options
- With or without display

Example Calibration and Load Information

Model	GSX40 Actuator with Load Cell
Serial No	6090825
Type	Compression Load Cell
Calibration Factor	2.1809 mV/V Full Scale
Calibration Full Scale Load	20,000 Pounds
Excitation Voltage	+/-10V
Linearity	<1%
Max Load	4000 Pounds
See Operation Manual for wiring and operation instructions	

Strain Gauge Function

- The strain gauge acts as a resistor in one leg of a Wheatstone bridge
- The strain gauge amplifier applies voltage across the bridge at A-A (excitation voltage), causing current to flow through the bridge
- The resistance of the strain gauge changes as a function of the force being applied
- The output voltage across B-B changes as a function of the load being applied to the load cell.

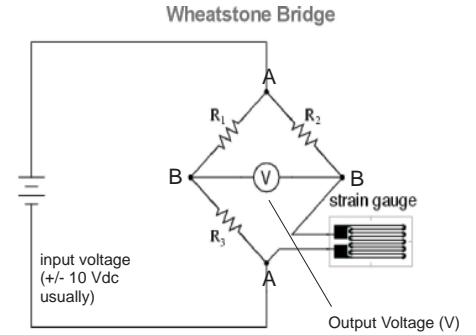

Typical System Wiring Diagram

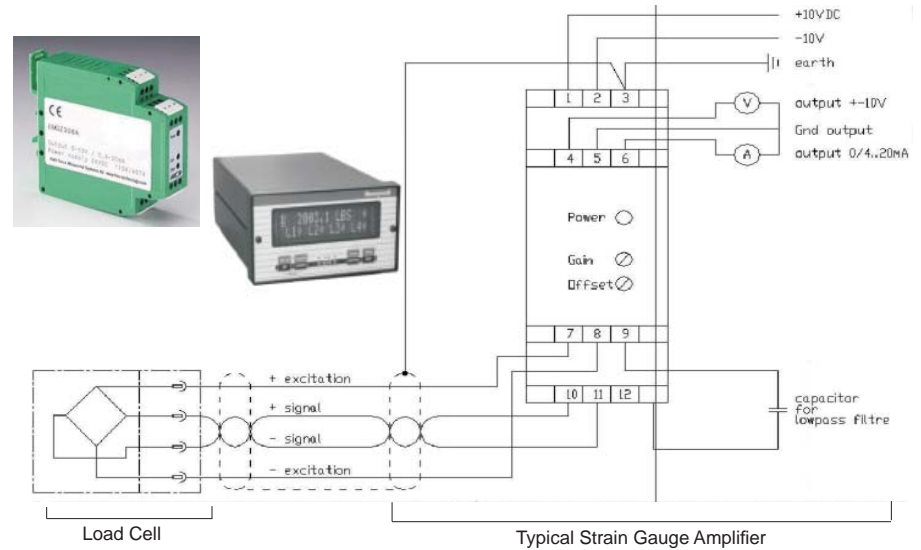

Exlar Corporation
 1470 Lake Drive West
 Chanhassen, MN 55317
 www.exlar.com
 Tel: 952-368-3434
 Fax: 952-368-4877